

September 2009

Description

Designed for General Purpose and Non-Incendive applications, TRUNKGUARD Series 200 Device Couplers (TG200) enable fast and easy implementation of fieldbus systems by connecting multiple devices to a main fieldbus trunk in FOUNDATION fieldbus™ H1 and PROFIBUS PA networks. TG200 Device Couplers are available in models that handle four to 20 fieldbus devices.

Protect Segments from Spur Faults

TRUNKGUARD Device Couplers provide electronic and fully auto-resetting spur short-circuit protection that prevent segment failure caused by single device faults. Utilizing a “FoldBack” technique, any spur that attempts to draw more than 48mA is automatically switched off and not permitted any current flow until the fault is removed. A trickle current is used to determine when the short has been removed. During a short, only 4-5mA is used. This is a significant advantage to “current-limiting” designs on competing units which hold a fault permanently on the segment at a higher than normal current level. This often results in segment failure by overloading the segment power supply. With removal of the short, TRUNKGUARD automatically reconnects the spur to the fieldbus segment.

Figure 1. TRUNKGUARD Device Couplers enable fast and easy implementation of FOUNDATION fieldbus™ and PROFIBUS PA systems.

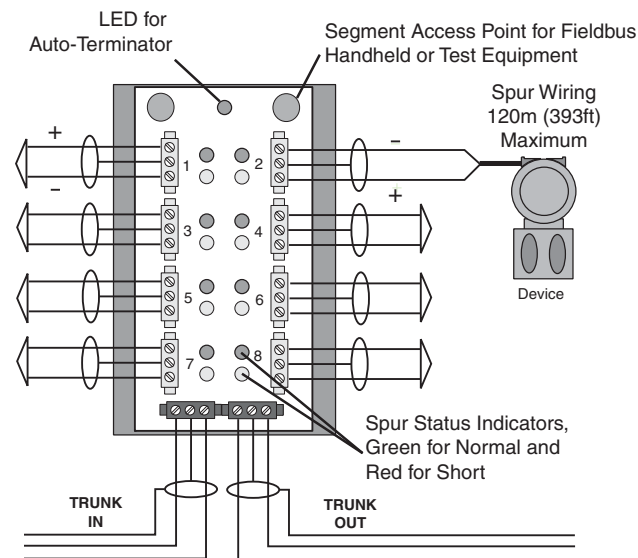

All product names are registered trademarks of their respective companies.

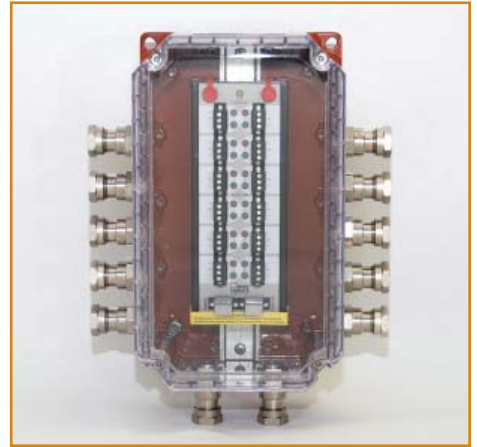

TRUNKGUARD Fieldbus Device Couplers, to speed specification and installation, are available in ready-to-install, field-mount enclosures complete with cable glands, or as DIN-rail mount units.

Features

- **Reduce commissioning delays.** Patented* “Automatic Segment Termination” eliminates the most common installation error: segment failure from under or over termination, and assures local parts of a segment will continue to function if remote parts are accidentally disconnected. (With the -MT option, the TG200 is supplied without auto-terminator when external termination is preferred.)
- **Speeds diagnostics and device configuration.** Diagnostic LEDs positively indicate status of spur power, any spur short circuits, and status of auto termination. The front panel features convenient connections for a fieldbus hand-held communicator.
- **Easy hazardous area installation.** ATEX/FM approvals allow installation in Zone 2 and Division 2 areas.

* United States Patent No. 7,355,438 and Great Britain Patent No. 2,407,237

Certifications



Factory Mutual (cFMus) US/Canada
File No. 3021946
Non-Incendive - Class I, Division 2,
Groups A, B, C, D; T5 Ta=70°C



Sira (ATEX) Zone 2
Certificate No. 04ATEX4111X
II 3 G D EEx nA [nL] IIC T5
Ta: -40°C to +70°C



CE Conformant - EMC Directive 89/336/EEC
EN 61326

TG200

TRUNKGUARD® Series Fieldbus Device Couplers (General Purpose and Non-Incendive Locations)

Specifications

Communications FOUNDATION Fieldbus™ H1 and PROFIBUS PA	Performance (continued)	Terminals Type: Removable terminals with screw-clamp retaining screws Wire Size: Handles sizes between 0.8-2.5mm ² /12-24AWG
Performance Supply Voltage: 9.5 to 32Vdc Maximum Segment Current: 1.5A Maximum Quiescent Current: TG204: 10mA@32V _{FB} ; 5mA@16V _{FB} TG208: 18mA@32V _{FB} ; 9mA@16V _{FB} TG20X: 23mA@32V _{FB} ; 11mA@16V _{FB} TG20W: 28mA@32V _{FB} ; 13mA@16V _{FB} * 3mA less with -MT option Maximum Spur Output Current: I _{Slim} = 48mA Spur Short Circuit Load: I _{Sec} = 5mA (32V), 3mA (16V) Spur Voltage Drop: 0.4V@20mA	Maximum Voltage Drop Trunk IN to OUT: 0.7V Terminator: 100Ω/1μF (Internal Automatic Segment Termination is standard; For manual termination, specify the -MT option with the MooreHawke model number "TRK-TERM" Trunk Terminator manually fitted on the final device coupler on the segment) Indicators Spur: GREEN (normal) RED (fault) Auto-Terminator: YELLOW LED is on when auto-termination is activated	Cable Glands (Device Couplers with Enclosures) Type: Armored/Unarmored Material: Nickel-plated brass Ambient Conditions Operating: -40°C to +70°C (-40°F to +158°F) Storage: -40°C to +85°C (-40°F to +185°F) Relative Humidity: 0-95%, non-condensing Surge Protection: EN61326, EN61000-4-5 1KV (1.2/50μsec) RF/EMI Immunity: 10V/m@80-1000MHz, 1kHz AM (IEC61326)

Environmental Advantages

TRUNKGUARD Device Couplers (TG200) can be ordered in ready-to-install, field-mount enclosures designed for applications in rugged and hazardous field conditions. Options include aluminum, GRP (Glass Reinforced Polyester) and stainless steel enclosures. All offer IP66 protection. Standard cable glands are nickel-plated brass, and can be ordered for use with unarmored or armored cable. Compound seal glands (for cable with inter-core spaces, i.e., unfilled cable), and quick-connect plugs and sockets are also available.

Non-Incendive Segment Design

TRUNKGUARD Fieldbus Device Couplers are approved for use in Zone 2/Division 2 areas as non-incendive systems for connection to fieldbus power supplies with nominal output parameters not exceeding 32V and 1.5A. When used in this way, the segment may be described as a non-

arcing trunk with energy-limited spurs. The trunk terminals may not be opened or disconnected while the segment is under power, and those terminals have the required IP30 covers over the screw heads. The spurs are all individually limited to 48mA and so may be opened or disconnected under power.

The field devices should be approved non-incendive with a voltage rating equal or greater than the selected power supply. As yet, there are only a limited range of approved non-incendive fieldbus devices available and it has become common practice to use intrinsically-safe devices, since the I.S. standards are more stringent than the non-incendive requirements. In effect, non-incendive design is intrinsically-safe design without consideration of faults and therefore limited to Zone2/Division 2. Entity-approved I.S. devices with the right voltage rating can be used and, even though they are I.S., in this application they are restricted to Zone 2/Division 2. The TG200 individual spur output does not exceed 24V when used with MooreHawke TRUNKGUARD TPS400 Fieldbus Power Supply, and therefore all FF816-type devices are compatible. Cable parameters still need to be taken into account, but are unlikely to be of concern. FISCO devices are generally approved with 17.5V maximum voltage, and would therefore be unsuitable in these applications. For intrinsically-safe applications, see the MooreHawke ROUTE-MASTER™ Fieldbus System.

Complete Fieldbus Device Coupler and Power Conditioner Systems

MooreHawke offers the isolated TRUNKGUARD TPS400 Fieldbus Power Supply for powering our TRUNKGUARD Fieldbus Device Couplers. The TPS400 provides TRUNKGUARD Device Couplers with up to 500mA per segment with load-sharing duplex modes and optional pluggable surge protection.

Ordering Information

Unit	Mounting/Enclosure Type	Number of Spurs	Gland/Connector Type	Gland Entry Size
TG2 TRUNKGUARD Device Coupler for General Purpose and Non-Incendive Locations	0 DIN-Rail Mount (No enclosure)	4 Fieldbus Spurs 8 Fieldbus Spurs X 10 Fieldbus Spurs W 12 Fieldbus Spurs	Not Applicable	-DIN (No cable glands) Universal DIN-style enclosure mounts on 32mm (EN50035) G-type and 35mm (EN50022) Top Hat DIN-rails
	5 Standard Aluminum, Solid Cover, IP66 Enclosure 6 Standard Aluminum, Clear Cover, IP66 Enclosure 4 Stainless Steel 316, IP66 Enclosure with E-Z vertically removable lid and bottom entry cable gland plate	4 Fieldbus Spurs 8 Fieldbus Spurs X 10 Fieldbus Spurs W 12 Fieldbus Spurs Y 20 Fieldbus Spurs	-A Unarmored Cable Glands (standard) -B Armored Cable Glands -C Compound Seal Cable Glands -D No Cable Glands -E M12 Turck Euro- fast™ Sockets -F 7/8-in Turck Mini- fast™ Sockets	GLAND ENTRY SIZE FOR: -O (standard) Unarmored Cable (7.5-11.9mm O.D.); Armored Cable (9.5-16.0mm O.D.) -S Unarmored Cable (3.0-8.0mm O.D.); Armored cable (5.5-12.0mm O.D.)
	2 Stainless Steel 316, IP66 Enclosure 3 GRP (Glass Reinforced Polyester), IP66 Enclosure	4 Fieldbus Spurs 8 Fieldbus Spurs X 10 Fieldbus Spurs W 12 Fieldbus Spurs	NOTES: 1. Gland/connector selection is for all entry ports. 2. Choices "-E" and "-F" have male sockets for "Trunk In" and female sockets for "Trunk Out" and "Spurs". 3. Weatherproof seals are provided for all glands, but not sockets	-MT Option: Specify for TG200 without auto-termination. NOTE: Auto-termination cannot be restored or reactivated on site. (e.g., TG258-A-O-MT)

NOTE: Device coupler with stainless steel 316 enclosure (4) and 20 fieldbus channels (Y) is composed of two 10-channel couplers (X) mounted in the enclosure.

When ordering, specify: Unit • Mounting or Enclosure Type • Number of Channels -Gland/Connector Type -Gland Entry Size
Model number example: **TG268-A-O**
 (8-Spur Device Coupler in Aluminum/Clear Cover Enclosure with Cable Glands for Unarmored Cable)
TG204-DIN
 (4-Spur Device Coupler for DIN-Rail Mounting)

Manual Trunk Terminator for Use with
 -MT Option, Specify: **TRK-TERM**

Figure 2. DIN-Rail Mounting Installation Dimensions (Base Units).

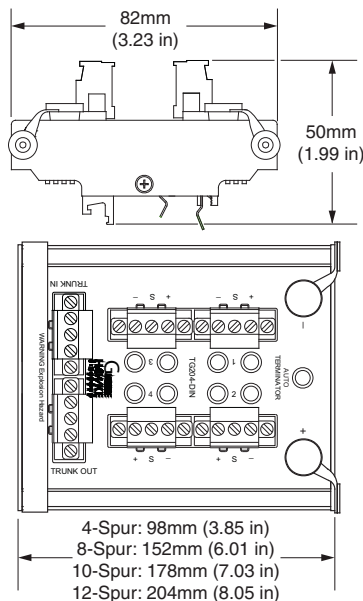
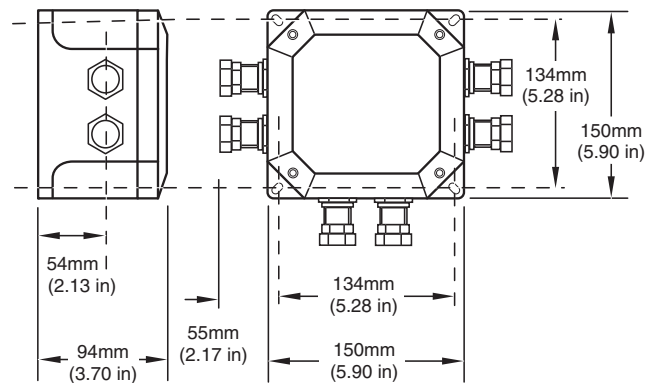

Figure 3. GRP (Glass Reinforced Polyester) Enclosure Installation Dimensions for TG234 (4-Spur) Models.



TG200

TRUNKGUARD® Series Fieldbus Device Couplers (General Purpose and Non-Incendive Locations)

Figure 4. Standard Aluminum Enclosure Installation Dimensions for 4-Spur (TG25/64), 8-Spur (TG25/68), 10-Spur (TG25/6X) and 12-Spur (TG25/6W) Models.

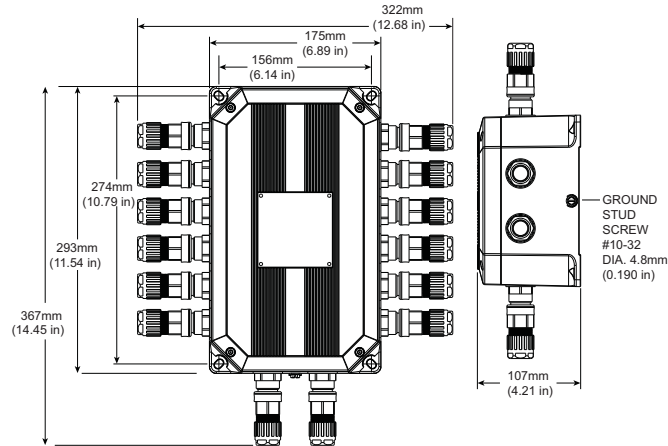

Figure 5. Electro-Polished Stainless Steel 316 Enclosure Installation Dimensions for 4-Spur (TG224) Models.

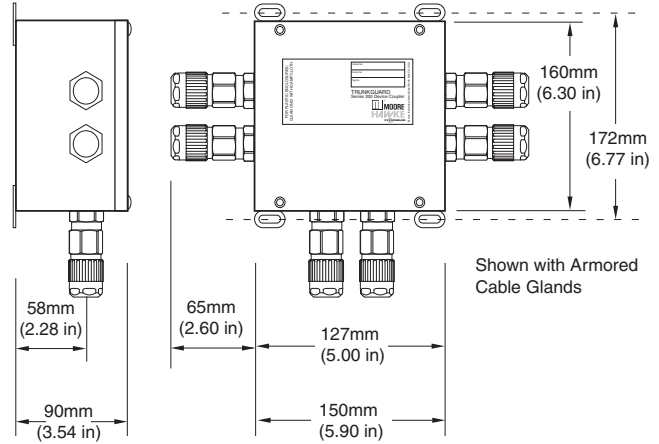

Figure 6. Electro-Polished Stainless Steel 316 Enclosure Installation Dimensions for 8- (TG228) and 10-Spur (TG22X) Models.

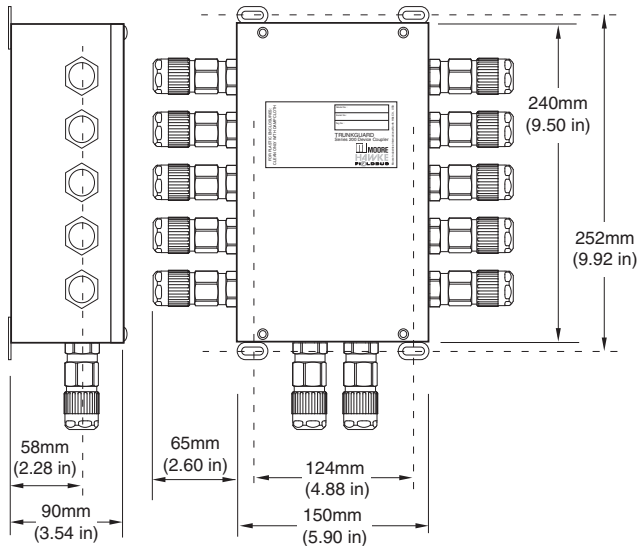
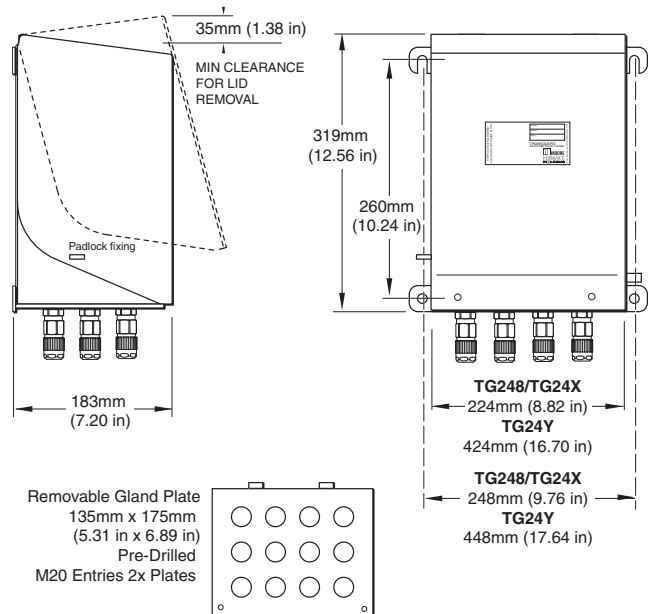

Figure 7. Stainless Steel 316 with E-Z Vertically Removable Lid and Bottom Entry Cable Gland Plate Installation Dimensions for 8-Spur (TG248), 10-Spur (TG24X), 12-Spur (TG2W) and 20-Spur (TG24Y) Models.



United States • info@miinet.com
Tel: (818) 894-7111 • FAX: (818) 891-2816
Australia • sales@mooreind.com.au
Tel: (02) 8536-7200 • FAX: (02) 9525-7296

Belgium • info@mooreind.be
Tel: 03/448.10.18 • FAX: 03/440.17.97
The Netherlands • sales@mooreind.nl
Tel: (0)344-617971 • FAX: (0)344-615920

China • sales@mooreind.sh.cn
Tel: 86-21-62491499 • FAX: 86-21-62490635
United Kingdom • sales@mooreind.com
Tel: 01293 514488 • FAX: 01293 536852

WORLDWIDE • www.miinet.com